

MECLIFT

VARIABLE REACH TRUCK

ML1612R ML1812R



**MULTIPURPOSE
MACHINE THAT
DELIVERS
IN EVERY SITUATION**



MECLIFT™ ML1612R/ML1812R

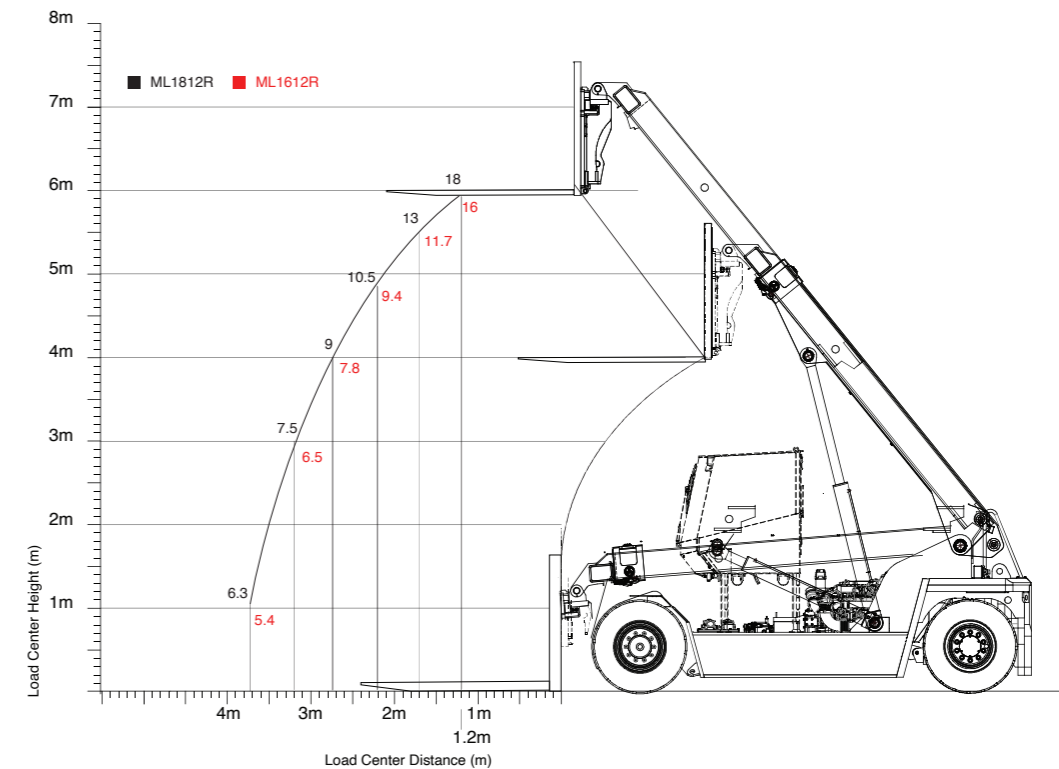

VARIABLE REACH TRUCK

Meclift™ ML1612R/ML1812R is a unique multipurpose machine. It is the only machine in the lifting capacity range of 16-18 tons, which can be operated inside containers.

It moves swiftly in confined spaces, such as warehouses and cargo vessels. In addition to heavy cargo lifting, ML1612R/ML1812R is perfect for practically any other material handling needs. Different kinds of Meclift attachments increase opportunities for using one machine for multiple purposes. It lifts 20-foot containers from fork pockets and stacks them up to 3-high. A hydraulically movable cabin ensures excellent visibility even when handling bulky objects. ML1612R/ML1812R is an environmentally friendly solution. Less work machinery on your yard means less fuel consumed. It also means more open space and better visibility, resulting in improved safety and less damage to your cargo. ML1612R/ML1812R is easy to transport in a 20-foot container or on a swap body vehicle. It is designed to operate reliably in demanding conditions. Supported by worldwide-known components and easily accessible spare parts, ML1612R/ML1812R is a secure choice.



"We use two Meclift ML1612R machines for loading and unloading steel coils into and out of containers in our port. These machines are very unique in design. Thanks to their low height and good reaching ability we are able to use them in other jobs as well. Sometimes we wonder how some of these jobs could be done without the Meclift trucks."

Mr. Kazim Keskin
Port Operation Manager
Borusan Lojistik
Gemlik, Turkey

"ML1812R is a thought-out concept, which features high-design-technology. Meclift is always looking for improvements. In addition to good service they are always."

Mr. René Kunst
Logistic & Transport
Vehicle management
Tata Steel, The Netherlands

"It makes specialized operations just so simple now"

Cezary Osipuk
DCT Gdansk S.A.



MECLIFT HANDLES YOUR CARGO SAFELY

WWW.MECLIFT.FI

MECLIFT™

ML1612R/ML1812R

Manufacturer	Mecalift Oy, Finland
Type	ML1812R [ML1612R]
Standard colors	Orange (RAL2004) and Blue (RAL5002)

Lifting properties	
Lifting capacity	18 000 kg [16 000kg]
Load center	1,200 mm
Lifting height	6,000 mm
Reach	2 500 mm
Lifting speed	Depends on boom position

Dimensions	
Length (without attachments)	5 575 mm
Width	2 160 mm
Height (min)	2 265 mm
Wheelbase	3 950 mm
Ground clearance	150 mm
ML1612R Weight (without attachments)	21 000 kg
ML1812R Weight (without attachments)	21 500 kg
Turning radius	5 250 mm
Standard forks	W x H x L 200 x 100 x 1 800

Technical specifications	
Power source	Diesel engine
Manufacturer	Cummins
Model	QSB6.7 Stage III / Tier 3
Power rating	142@1900 kW@rpm
Peak torque	930@1300 Nm@rpm
Model	B6.7 Stage V / Tier 4
Power rating	149@2200 kW@rpm
Peak torque	990@1300 Nm@rpm
Transmission	3 speed automatic
Manufacturer	ZF
Model	Powershift ZF WG171
Driving speed	28 km/h

Drive axle	
Manufacturer	Kessler
Model	D81
Service brake	Hydraulic wet disc
Parking brake	Spring powered disc
Tyres	
Front	4 x 12.00-20
Rear	2 x 12.00-20

Options

MECLIFT

Variable Reach Truck

Mecalift Oy

Ristinarkuntie 20
FI-33560 Tampere, Finland
Tel. +358 400 403 593
sales@meclift.fi
www.meclift.fi

